

Technischer Rider (grosser Theatersaal)

Stand: 14.08.2017

Audiotechnik

Saal Music-System L / R			
2	System Controller / Endstufe	L Acoustics	LA8
2	Topteil Wide	L Acoustics	ARCS Wide
4	Topteil Focus	L Acoustics	ARCS Focus
2	Subwoofer	L Acoustics	SB 18m
Saal Vocal-System L / C / R			
3	System Controller / Endstufe	L Acoustics	LA4X
3	Topteil Wide	L Acoustics	ARCS Wide
6	Topteil Focus	L Acoustics	ARCS Focus
Bühnen Subwoofer			
2	Subwoofer	L Acoustics	SB 18
Bühnen Monitoring			
2	System Controller / Endstufe	L Acoustics	LA4X
6	Lautsprecher Aufgänge Bühne	L Acoustics	X8
4	Lautsprecher Dusche Bühne	L Acoustics	X12
2	Lautsprecher Monitor Bühnenportal	L Acoustics	X15 HiQ
10	Downhanger Monitorlautsprecher (Aufgänge, Dusche)	Doughty	Modular
Saal Produktions-Regie „FOH“			
1	Mischpult 72 IN / 8 Stereo IN / DANTE	Yamaha	CL 5
1	Sprechstelle; Mikrofon mit Taster	Shure	MX412D/C
Saal, geschlossene Regie, AV- Zentrale			
1	Gong Player	Brightsign	HD1023
1	Network Stream Player	Crestron	CEN-NSP-1
1	Audiomatrix 8/8 mit DANTE-Interface	BSS	BLU-806
1	Mischpult 32 IN / 8 Stereo IN / DANTE	Yamaha	QL1
Bühnenregie AUDIO			
2	Stagebox 16/8 DANTE	Yamaha	RIO 16/8
1	Stagebox 32/24 DANTE	Yamaha	RIO 32/24
6	Funkmikrofon-Empfänger 4 Kanal	Shure	ULXD4QE-K51
22	Taschensender	Shure	ULXD1-K51
2	Handsender	Shure	ULXD2-K51
Saal Hörbehinderten Anlage			
1	FM Grossraumsender	Phonak	116-1938
1	WallPilot	Phonak	Roger Wall Pilot
12	FM Empfänger	Phonak	Roger MyLink
EG Foyer / WC			
1	Audioverstärker 70V; 200W	LAB	E 2:2
6	Lautsprecher	JBL	Control 25-1
1	Sprechstelle; Mikrofon mit Taster	Shure	MX412D/C
1. OG Foyer			
1	Audioverstärker 70V; 200W	LAB	E 2:2
4	Lautsprecher	JBL	Control 25-1
2. OG Foyer			
1	Audioverstärker 70V; 200W	LAB	E 2:2
2	Lautsprecher	JBL	Control 25-1

UG Garderoben

1	Audioverstärker 70V; 200W	LAB	E 2:2
6	Lautsprecher	JBL	Control 25-1

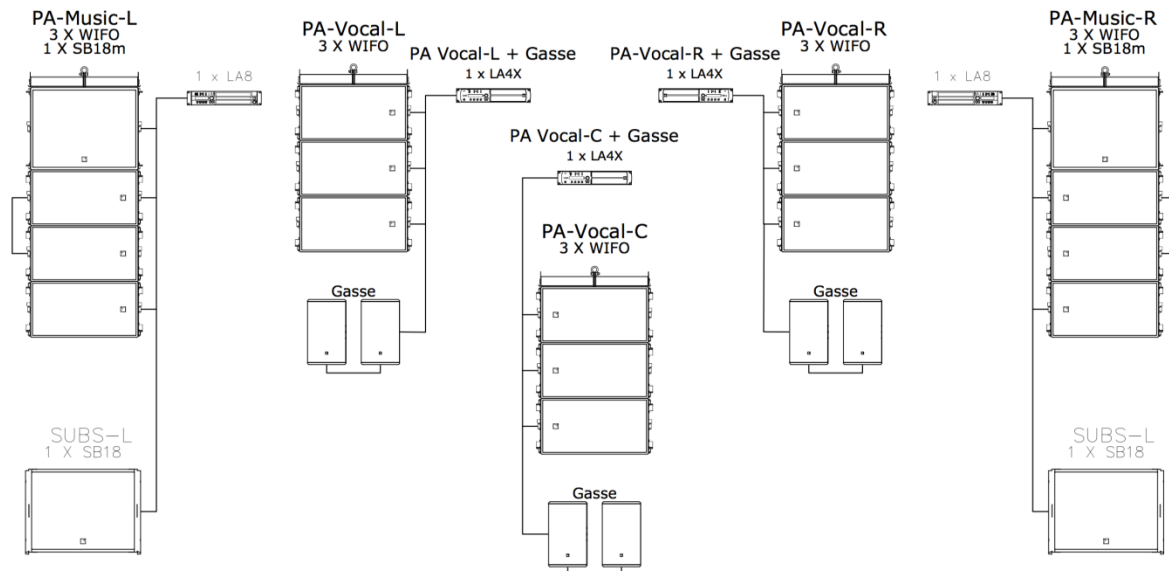

Lichttechnik

Saal Produktions-Regie „FOH“

1	Lichtsteuerung	ETC	GIO
1	Faderwing	ETC	2 x20
1	Lichtsteuerung	ETC	Color Source 40 AV
3	DMX Gateway 3 Port	ELC	DLN6X
2	DMX Gateway 6 Port	ELC	DLN3TM
2	Sub- Splitter DMX / RDM	Swisson	XPD-28

Bühnenregie LICHT

4	Dimmer 12 x 2.5kW, Socapex	ETC	ALEX
1	DMX Gateway 6 Port	ELC	DLN3TM
6	Socapex Breakout 6x T23	ASL	ER23119M6T23

Schweinwerfer Konventionell

12	Profilscheinwerfer 25-50°	ETC	Source4
12	Fresnelscheinwerfer 1000W Profilscheinwerfer	Arri	ST 1
12	Torblende 4 Doors	Arri	L2.39870.0

LED Fluter

6	LED Washlight 36 x RGBW	CLF	Ares
6	Diffusor Filter 54.2° Acryl	CLF	#156246

Moving Lights

6	Spot / Profile LED	Robe	DL7S LED
6	Wash LED	Robe	Spiider

Videotechnik

Video Übertragungstechnik

1	Videoprojektor		
2	Digital Media- Empfänger	Crestron	DM-RMC-100-C
3	Digital Media- Sender	Crestron	DM-TX-201-C
div.	HD-SDI Anschlüsse im Saal		

Medien-Steuerung

Saal Alte Regie, AV- Zentrale			
1	SPS Steuerung	Crestron	DMP53-4K-150-C
1	KNX Schnittstellenmodul	Crestron	CGEIB-IP
1	DMX Schnittstellenmodul	Crestron	CGDMX-512B
1	Touchpanel 10.5"	Crestron	TSW 1060
Saal Produktions-Regie „FOH“			
1	Touchpanel 10.5"	Crestron	TSW 1060
1	Tischfuss zu Touchpanel	Crestron	TSW 1060-TTK
Bühnenregie AUDIO			
1	Touchpanel 10.5"	Crestron	TSW 1060
1	Tischfuss zu Touchpanel	Crestron	TSW 1060-TTK
Mobiles Bedieninterface Technik			
1	Mobiles Touchpanel; inkl. Crestron APP	Apple	Ipad
1	Induktive Ladestation	Launchport	Baste Station